



# Parts and Accessories Installation Instructions

## Auxiliary connector retrofit for external audio sources

**BMW 3 Series (E46), 5 Series (E39) from 09/02**

**X5 (E53) from 10/02**

**These installation instructions are only valid for cars with SA 602/609/661+650 from 09/02**

---

### Important information

Subject to technical modifications.

### Target group

These installation instructions are primarily designed for use within the BMW dealership organisation and by authorised BMW service companies. In any event the target group for these installation instructions is specialist personnel trained on BMW cars with the appropriate specialist knowledge.

All work must be completed using the latest BMW repair manuals, circuit diagrams, servicing manuals and work instructions in a rational order using the prescribed tools (special tools) and observing current health and safety regulations.

### Installation information

Ensure that the cables/lines are not kinked or damaged as you install them in the car.

The installed cables are to be secured with cable ties.

### Installation time

Approx. 1,5 hours, but this may vary depending on the condition of the car and the equipment in it.

### Pictograms



denotes instructions that draw your attention to special features. ◀

◀ denotes the end of the instruction or caution text. ◀

### List of special equipment

The following special equipment must be taken into consideration when installing the retrofit kit. The various sections contain corresponding information.

**SA 602** On-board monitor

**SA 609** Navigation system

**SA 661+650** BMW Business radio with CD drive

### Retrofit kit No.

65 12 0 153 501

65 12 0 153 502

65 12 0 153 503

## **Special tools required**

E46 installation wedge (00 9 321)

E39 radio puller (65 1 100)

Special E46 radio tool (65 1 110) for SA 602 only

## Contents

Section	Page
1. Preparations.....	4
2. Parts list .....	5
3. To install and connect the AUX connector wiring harness in E46 cars .....	7
4. To install and connect the AUX connector wiring harness in E39 cars .....	9
5. To install and connect the AUX connector wiring harness in E53 cars .....	10
6. Concluding work and coding .....	11
7. Circuit diagram .....	12

## 1. Preparations

	<b>TIS instruction No.</b>
Conduct a brief test	- - -
Disconnect the negative pole of the battery	12 00 ...
<b>The following components must be removed first of all:</b>	
Glove compartment on the right	51 16 360
Radio receiver (cars with SA 661+650 only)	65 11 030
Multi Information Display (E39/E53 cars with SA 661+650 only)	65 81 010
On-board monitor (cars with SA 602/609 only)	65 52 013

## 2. Parts list

### E46 with SA 661+650 only

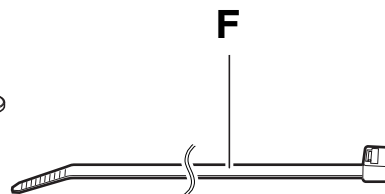
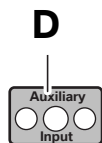
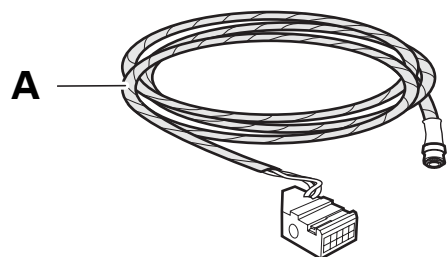

046 1115 Z

### E39/E53 with SA 661+650 only

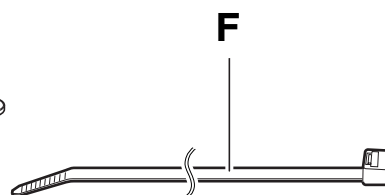
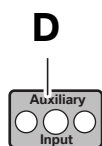
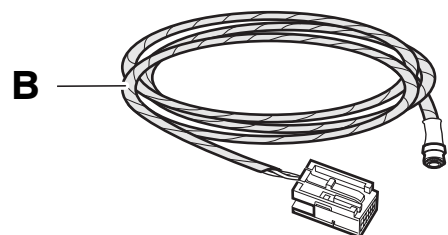

046 1116 Z

### E39/E46/E53 with SA 602/609 only

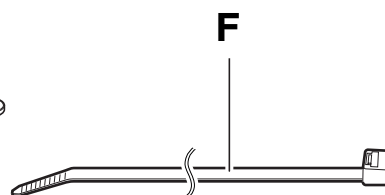
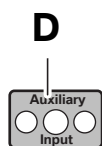
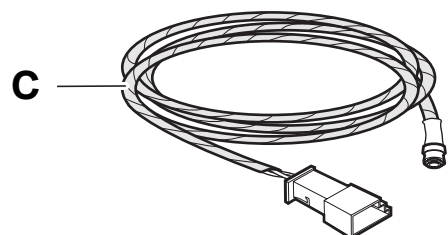

046 1117 Z

## Legend

- A** E46 AUX wiring harness with SA 661+650
- B** E39/E53 AUX wiring harness with SA 661+650
- C** E46/E39/E53 AUX wiring harness with SA 602/609
- D** Mounting plate
- E** Philips screw (2x)
- F** Cable tie (5x)
- G** Locking bar (E46 with SA 661+650 only)

## 2. Connection diagram

### E46 with SA 661+650 only

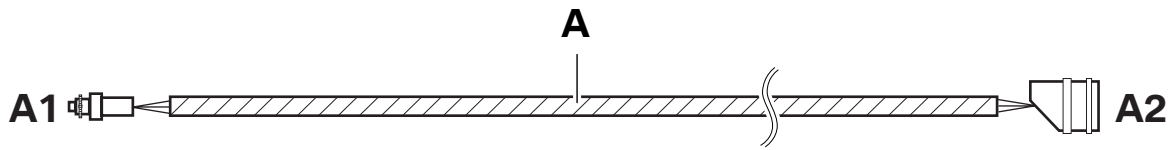

046 1118 Z

Item	Description	Signal	Cable colour / Cross-section	Connection location in the car	Abbreviation / Slot
A	AUX connector wiring harness	---	---	<b>E46 with SA 661+650 only</b>	---
A1	Pawl socket 3.5 mm	---	---	In glove compartment	---
A2	10-pin GR socket casing	---	---	To radio plug <b>X18126</b>	X18805

### E39/E53 with SA 661+650 only

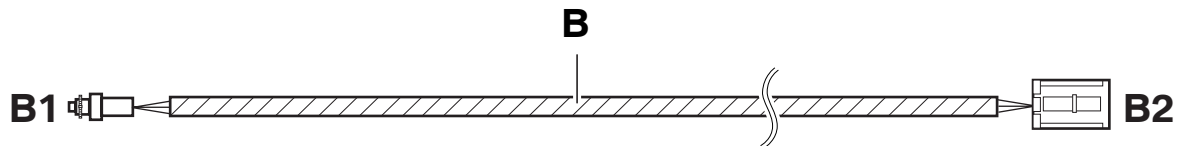

046 1119 Z

Item	Description	Signal	Cable colour / Cross-section	Connection location in the car	Abbreviation / Slot
B	AUX connector wiring harness	---	---	<b>E39/E53 with SA 661+650 only</b>	---
B1	Pawl socket 3.5 mm	---	---	In glove compartment	---
B2	SW 12-pin socket casing	---	---	To radio plug <b>X18126</b>	X13598

### E39/E46/E53 with SA 602/609 only

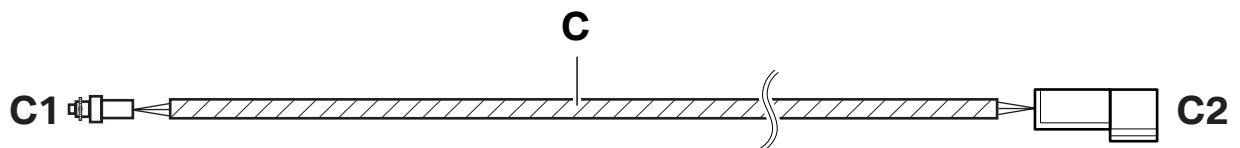

046 1120 Z

Item	Description	Signal	Cable colour / Cross-section	Connection location in the car	Abbreviation / Slot
C	AUX connector wiring harness	---	---	<b>E39/E46/E53 with SA 602/609 only</b>	---
C1	Pawl socket 3.5 mm	---	---	In glove compartment	---
C2	SW 3-pin plug casing	---	---	To plug <b>X14118</b>	X14118

### 3. To install and connect the AUX connector wiring harness in E46 cars

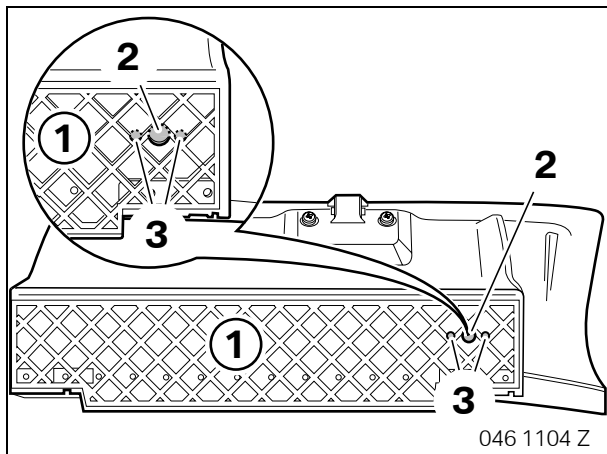

 All holes must be drilled precisely as shown in the illustration. ◀

Drill a hole (2) in the rear of the glove compartment (1) with an 8 mm twist drill bit.

Drill the holes (3) using a 3 mm twist drill bit.

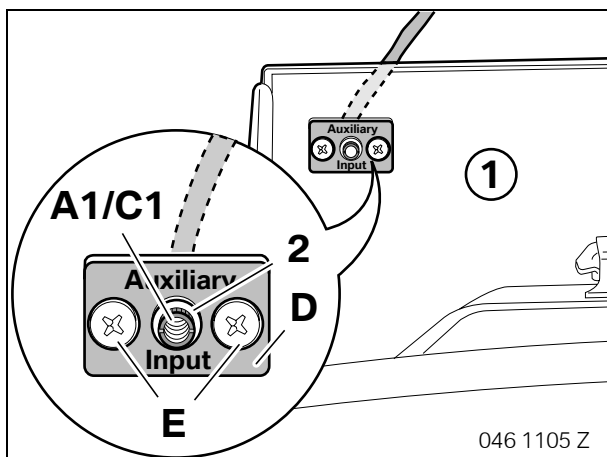

Insert branch **A1/C1** in the glove compartment (1) and secure it to the mounting plate **D** with a knurled nut (2).

Secure the mounting plate **D** to the glove compartment (1) using Philips screws **E**.

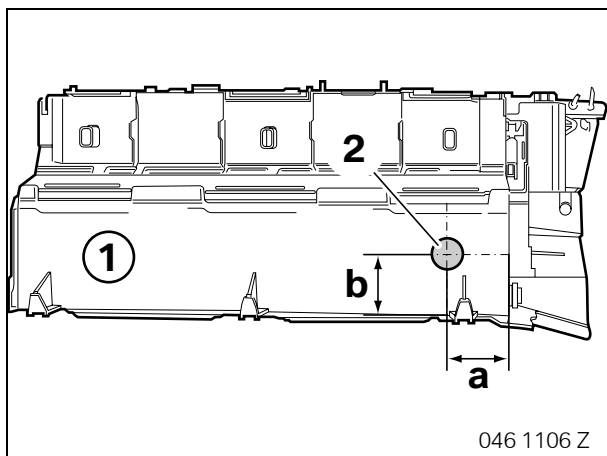

Drill a hole (2) in the trim (1) with a 3 mm twist drill bit through which you can thread the AUX connector wiring harness.

Dimension **a** 40 mm

Dimension **b** 45 mm

Enlarge the hole (2) to a diameter of 20 mm.

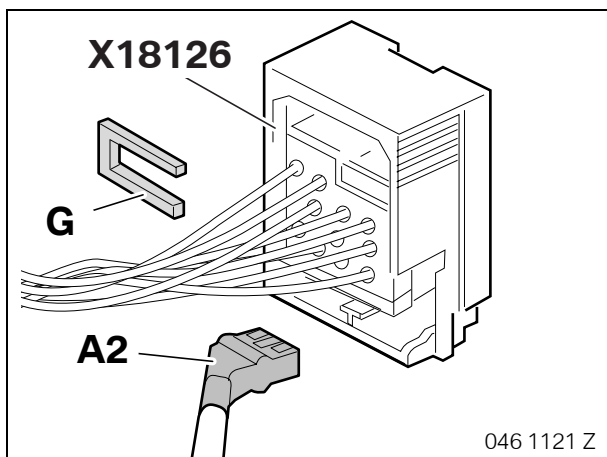

#### Cars with SA 661+650 only

Connect branch **A2** to plug **X18126** and secure it with the locking bar **G**.

3. To install and connect the AUX connector wiring harness in E46 cars

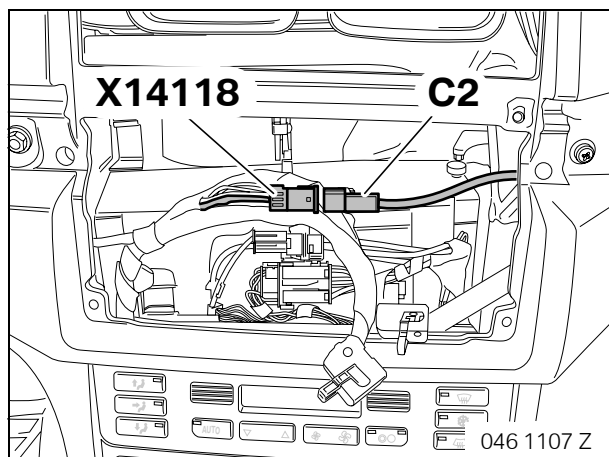

**Cars with SA 602/609 only**

Connect branch **C2** to tied back plug **X14118**.



#### 4. To install and connect the AUX connector wiring harness in E39 cars

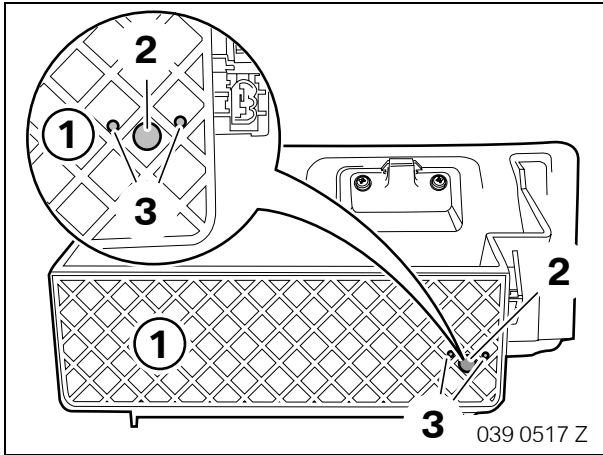

▶ All holes must be drilled precisely as shown in the illustration. ◀

Drill a hole (2) in the rear of the glove compartment (1) with an 8 mm twist drill bit.

Drill the holes (3) using a 3 mm twist drill bit.

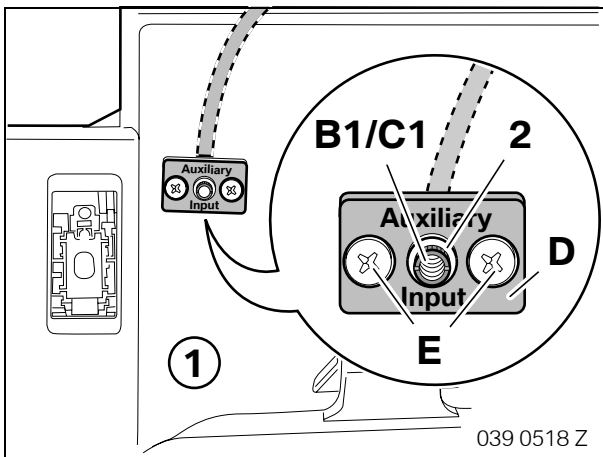

Insert branch **B1/C1** in the glove compartment (1) and secure it to the mounting plate **D** with a knurled nut (2).

Secure the mounting plate **D** to the glove compartment (1) using Philips screws **E**.

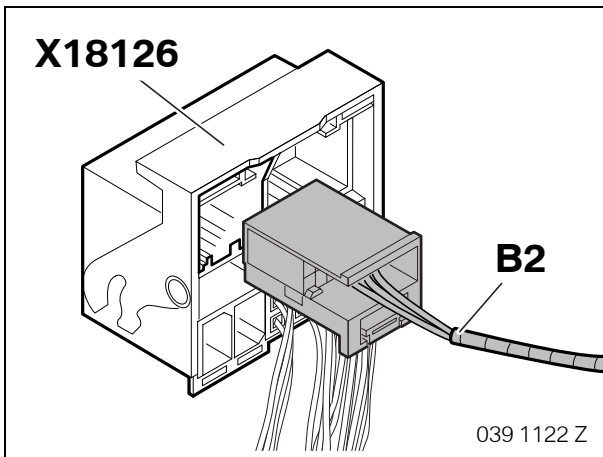

#### Cars with SA 661+650 only

Connect branch **B2** to plug **X18126**.

▶ If the plug **X13321** is already in the car, the cables from branch **B2** must be disconnected and connected to the same pins in the plug in the car **X13321**. ◀

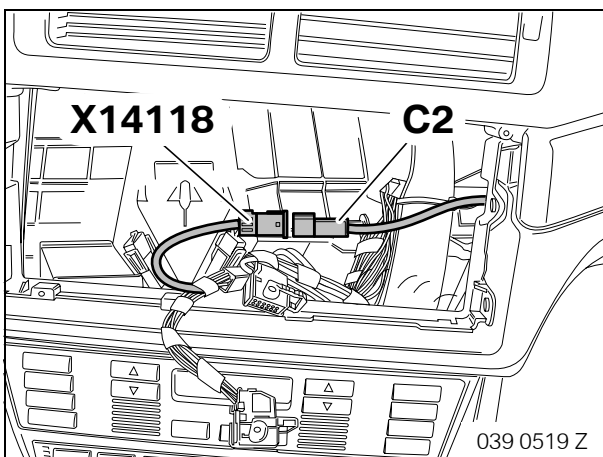

#### Cars with SA 602/609 only

Connect branch **C2** to tied back plug **X14118**.

## 5. To install and connect the AUX connector wiring harness in E53 cars

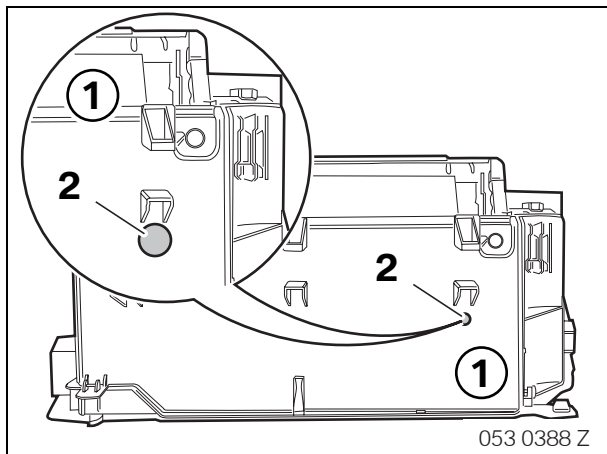

▶ All holes must be drilled precisely as shown in the illustration. ◀

Drill a hole (2) in the trim (1) through the rear of the glove compartment with an 8 mm twist drill bit.

Open the glove compartment and enlarge the hole (2) to a diameter of 20 mm.

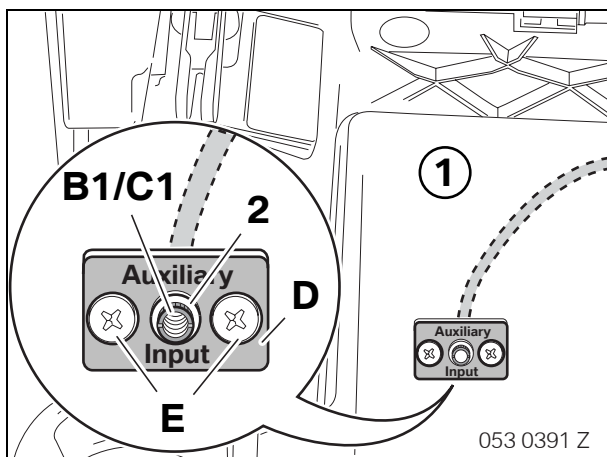

Insert branch **B1/C1** in the glove compartment (1) and secure it to the mounting plate **D** with a knurled nut (2).

Mark the mounting holes and drill them with a 3 mm twist drill bit.

Secure the mounting plate **D** to the glove compartment (1) using Philips screws **E**.

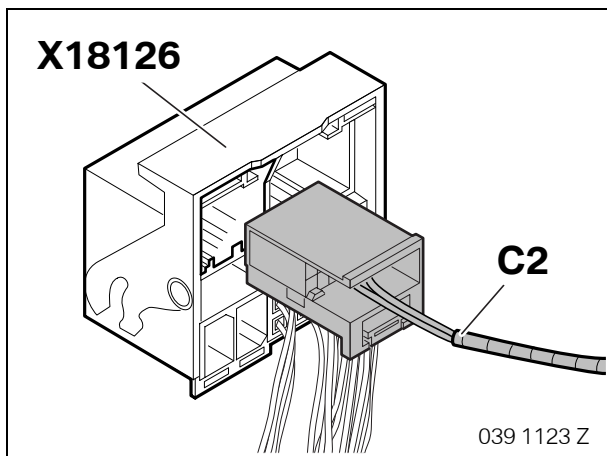

### Cars with SA 661+650 only

Connect branch **C2** to plug **X18126**.

▶ If the plug **X13321** is already in the car, the two cables from branch **C2** must be disconnected and connected to the same pins in the plug in the car **X13321**. ◀

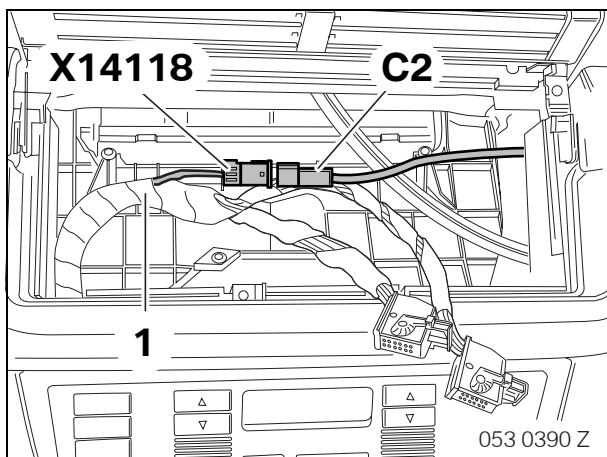

### Cars with SA 602/609 only

Connect branch **C2** to tied back plug **X14118**.

## 6. Concluding work and coding

 This retrofit system does not require coding. ◀

- Connect battery
- Conduct a brief test with DIS/GT1
- Conduct a function test
- Re-assemble the car

## 7. Circuit diagram

### E46 with SA 661+650 only

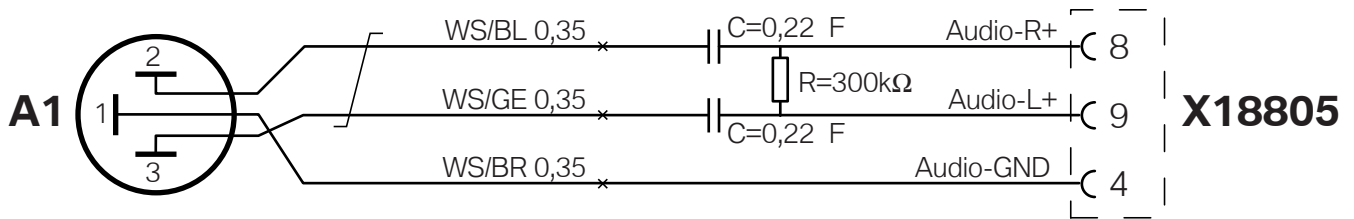

### E39/E53 with SA 661+650 only

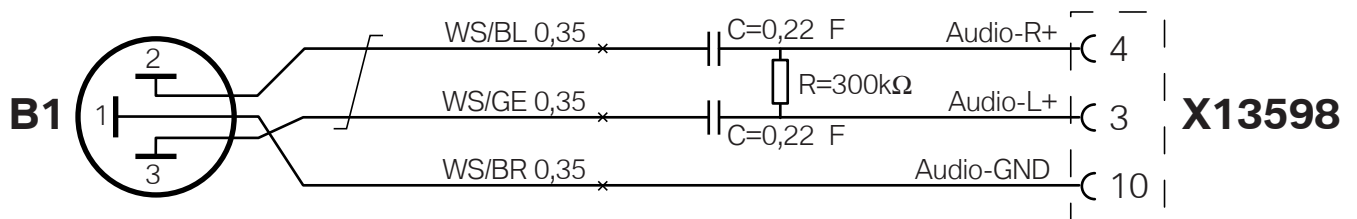

### E39/E46/E53 with SA 602/609 only

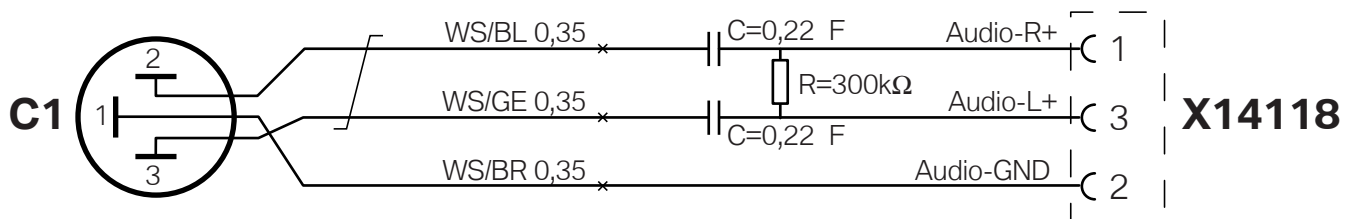

### Legend

A1	Pawl plug 3.5 mm
X18805	10-pin GR socket casing
B1	Pawl plug 3.5 mm
X13598	SW 12-pin socket casing
C1	Pawl plug 3.5 mm
X14118	SW 3-pin plug casing

### Cable colours

BL	blue
BR	brown
GE	yellow
GR	grey
SW	black
WS	white